

NUMBER NINETY

'TRADER' SERVICE SHEETS

FERGUSON 350
ALL-WAVE A.C. SUPERHET

TWO volume controls are provided in the Ferguson 350 7-valve (plus rectifier) A.C. all-wave receiver. One varies the bias on the H.F. and F.C. stages and is used as a sensitivity control, while the other is fitted in the L.F. amplifier and is employed as the usual volume control.

The receiver has a tapped mains transformer making it suitable for mains of 100 and 200-250 V and is provided with connections for a gramophone pick-up.

CIRCUIT DESCRIPTION

Aerial input via coupling coils **L1, L2** (S.W.), **L3** (M.W.), and **L4** (L.W.) to tuned circuit, comprising condenser **C35** and coils **L5, L6** (S.W.), **L7** (M.W.), and **L8** (L.W.), which are switched separately to cover four wavebands. Provision for connection of special impedance matched transmission line to terminals **A1** and **A2**.

by condensers **C42, C43** (S.W.), **C46** (M.W.), and **C47, C12** (L.W.); anode reaction coils **L19, L20** and **L21**.

Sensitivity control by variable resistance **R5** in **V1** and **V2** common cathode circuit which varies fixed G.B. applied.

Third valve (**V3, National Union 6D6**) is a variable-mu H.F. pentode operating as intermediate frequency amplifier with tuned-primary tuned-secondary transformer couplings **L22, L23** and **L24, L25**.

Intermediate frequency 456 KC/S.

Diode second detector forms part of double diode triode valve (**V4, National Union 85**). Second diode fed by condenser **C20** provides D.C. potential which is developed across load resistance **R17** and fed back through decoupling circuits as G.B. to H.F. and F.C. valves, giving automatic volume control.

Audio-frequency component in output from signal diode is developed across manual volume control **R11** and passed

across primary of push-pull speaker input transformer **T2**.

H.T. current is supplied by full-wave rectifying valve (**V8, National Union 80**). Smoothing by speaker field coil **L28** and electrolytic condensers **C27, C28**. H.F. by-passing in mains circuit by condenser **C30**.

COMPONENTS AND VALUES

Resistances		Values (ohms)
R1	V1 cont. grid decoupling	100,000
R2	V1, V2 and V3, S.G.'s H.T. potential divider	20,000
R3		50,000
R4	V1 and V2 fixed G.B. resistance	200
R5	V1 and V2 sensitivity control	3,000
R6	V2 tet. cont. grid decoupling	100,000
R7	V2 osc. grid resistance	50,000
R8	V2 osc. anode resistance	25,000
R9	V3 G.B. resistance	500*
R10	I.F. stopper	25,000
R11	V4 signal diode load; vol. control	500,000
R12	V4 grid resistance	1,000,000
R13	V4 anode decoupling	100,000
R14	V4 anode resistance	250,000
R15	V4 G.B. resistance	2,000
R16	A.V.C. line decoupling	1,000,000
R17	V4 A.V.C. diode load	1,000,000
R18	V5 grid resistance	1,000,000†
R19	V5 G.B. resistance	1,000
R20	V5 anode decoupling	25,000
R21	Tone control	100,000
R22	V6 and V7 G.B. resistance	670
R23†	C4 shunt	3,000

* May be 2,000 O. † May be 500,000 O.
‡ May not appear in some chassis.

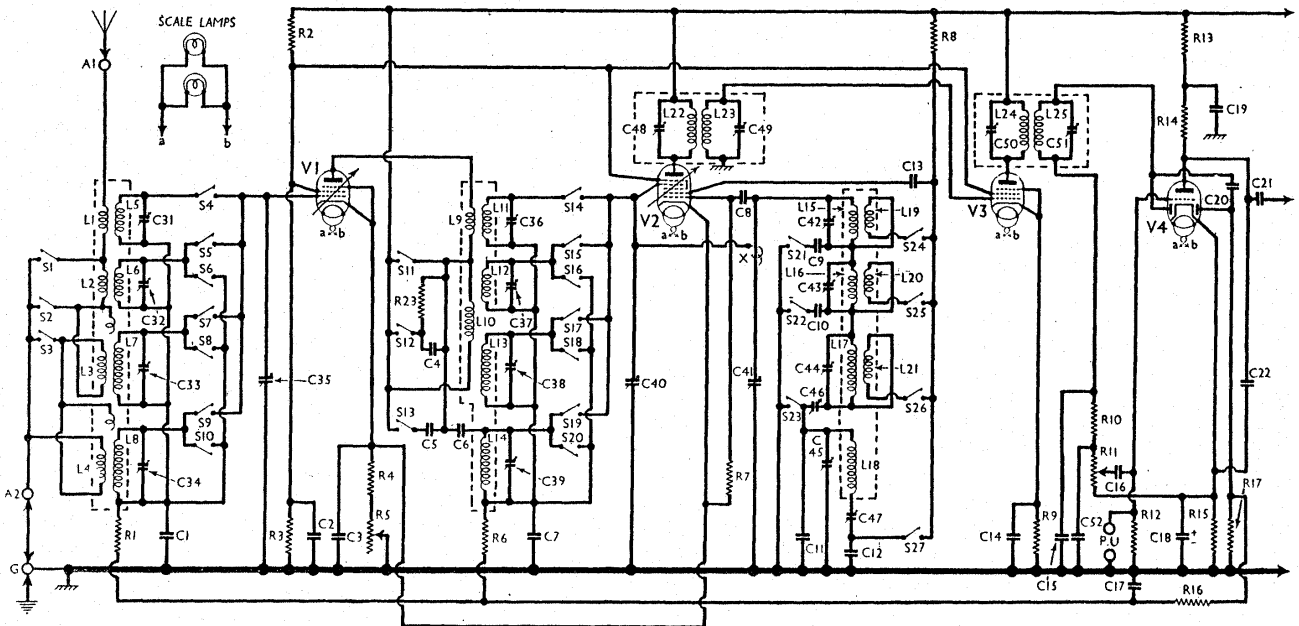

First valve (**V1, National Union 6D6**), is a variable-mu pentode operating as signal frequency amplifier with tuned-secondary transformer coupling to heptode frequency changer (**V2, National Union 6A7**). Primary **L9, L10**; secondaries **L11, L12** (S.W.), **L13** (M.W.), and **L14** (L.W.) are tuned by **C40**, and are independently switched. Oscillator grid coils **L15, L16** (S.W.), **L17** (M.W.) and **L18** (L.W.) are tuned by **C41**; tracking

via coupling condenser **C16** to grid of **V4** triode section, which operates as first L.F. amplifier. Provision for connection of gramophone pick-up.

Resistance-capacity coupling by **R14, C21** and **R18** to second triode L.F. amplifier (**V5, National Union 76**). Series fed transformer coupling by **T1** to push-pull output stage comprising two triodes (**V6, V7, National Union 45's**). Variable tone control by R.C. filter **R21, C25**

Circuit diagram of the Ferguson Model 350 all-wave A.C. superhet. The numbers in circles refer to the connections of the speaker plug and socket, a numbered diagram of which, viewed from the free ends of the pins, is inset in the extension of the diagram on the opposite page.

Condensers		Values (μF)
C1	V1 cont. grid decoupling ..	0.1
C2	V1, V2, V3, S.G.'s by-pass ..	0.1
C3	V1, V2 cathodes by-pass ..	0.1
C4	H.F. trans. switch blocking	0.00003
C5	condensers ..	0.001
C6	H.F. trans. L.W. capacitance	0.00003
C7	coupling ..	0.1
C8	V2 tet. cont. grid decoupling ..	0.0001
C9	V2 osc. grid condenser ..	0.0055
C10	Oscillator S.W. trackers ..	0.0015
C11	Oscillator L.W. trimmer, fixed ..	0.00003
C12	Oscillator L.W. tracker, fixed ..	0.0005
C13	Oscillator anode condenser ..	0.002
C14	V3 cathode by-pass ..	0.1
C15	I.F. by-pass ..	0.0001
C16	L.F. coupling to V4 triode ..	0.01
C17	A.V.C. line decoupling ..	0.02
C18*	V4 cathode by-pass ..	5.0
C19	V4 anode decoupling ..	0.1
C20	Coupling to V4 A.V.C. diode ..	0.00025
C21	L.F. coupling to V5 ..	0.01
C22	V4 anode I.F. by-pass ..	0.00025
C23*	V5 cathode by-pass ..	5.0
C24	V5 anode decoupling ..	0.25
C25	Part of tone cont. filter ..	0.1
C26	H.T. line by-pass ..	0.1
C27*	H.T. smoothing ..	12.0
C28*	H.T. smoothing ..	12.0
C29	V6, V7 G.B. resistor by-pass ..	0.5
C30	Mains H.F. by-pass ..	0.1
C31	Aerial circuit S.W. trimmers ..	—
C32	Aerial circuit M.W. trimmer ..	—
C33	Aerial circuit L.W. trimmer ..	—
C34	Aerial circuit tuning ..	—
C35	H.F. transformer S.W. trimmers ..	—
C36	H.F. trans. M.W. trimmer ..	—
C37	H.F. trans. L.W. trimmer ..	—
C38	H.F. transformer tuning ..	—
C39	Oscillator tuning ..	—
C40	Oscillator S.W. trimmers ..	—
C41	Oscillator M.W. trimmer ..	—
C42	Oscillator L.W. trimmer ..	—
C43	Oscillator M.W. tracker ..	—
C44	Oscillator L.W. tracker ..	—
C45	Oscillator M.W. tracker ..	—
C46	Oscillator L.W. tracker ..	0.0004

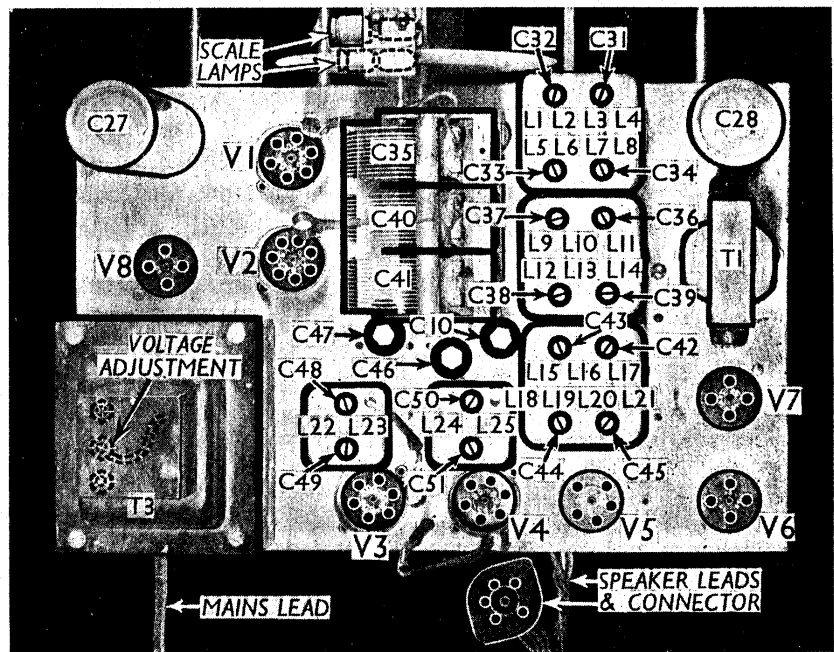

Plan view of the chassis. All trimmers are clearly marked. C10 is in parallel with two fixed condensers.

Condensers (contd.)		Values (μF)
C47	Oscillator L.W. tracker ..	0.0005
C48	1st I.F. trans. pri. tuning ..	—
C49	1st I.F. trans. sec. tuning ..	—
C50	2nd I.F. trans. pri. tuning ..	—
C51	2nd I.F. trans. sec. tuning ..	—
C52	I.F. by-pass ..	0.0001

* Electrolytic. † Variable. ‡ Pre-set. § Two fixed and one pre-set in parallel.

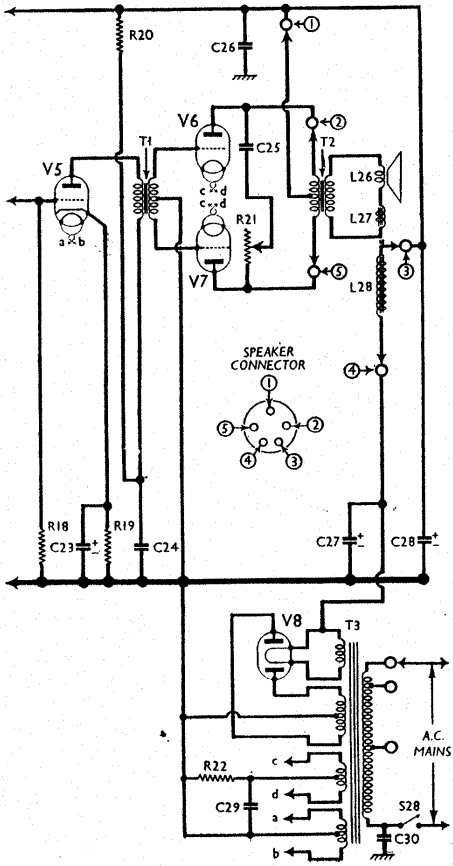

Other Components		Approx. Values (ohms)
L1	S.W. aerial coupling coils ..	0.5
L2	M.W. aerial coupling coil ..	1.3
L3	L.W. aerial coupling coil ..	27.5
L4	L.W. aerial coupling coil ..	120.0
L5	S.W. aerial tuning coils ..	Very Low
L6	M.W. aerial tuning coil ..	0.2
L7	L.W. aerial tuning coil ..	3.8
L8	M.W. aerial tuning coil ..	17.0
L9	L.W. aerial tuning coil ..	0.7
L10	H.F. transformer primary ..	28.0
L11	H.F. transformer S.W. secondaries ..	Very Low
L12	H.F. transformer M.W. sec. ..	0.2
L13	H.F. transformer L.W. sec. ..	3.8
L14	H.F. transformer L.W. sec. ..	15.0
L15	Oscillator S.W. tuning coils ..	Very Low
L16	Oscillator M.W. tuning coil ..	0.2
L17	Oscillator L.W. tuning coil ..	4.5
L18	Oscillator L.W. tuning coil ..	4.6
L19	Oscillator anode coils ..	0.6
L20	Oscillator anode coils ..	1.2
L21	Oscillator anode coils ..	0.8
L22	1st I.F. trans. Pri. ..	9.0
L23	1st I.F. trans. Sec. ..	13.0
L24	2nd I.F. trans. Pri. ..	9.0
L25	2nd I.F. trans. Sec. ..	13.0
L26	Speaker speech coil ..	2.8
L27	Hum neutralising coil ..	0.3
L28	Speaker field coil ..	1,000.0
T1	Push-pull input trans. Pri. total ..	4,000.0
T2	Speaker input trans. Pri. total ..	500.0
T3	Mains trans. Pri. total ..	0.5
	6.3V heat. sec. ..	17.5
	2.5V heat. sec. ..	0.15
	Rect. fil. sec. ..	0.05
	H.T. sec. ..	0.1
S1-S27	Waveband switches ..	185.0
S28	Mains switch, ganged R11 ..	—
X	Small coupling ..	—

DISMANTLING THE SET

Removing Chassis.—First remove the six control knobs (recessed grub screws) and the four bolts (with washers and rubber washers) holding the chassis to cabinet bottom. Next remove socket on right-hand side of cabinet for speaker leads (two round-head wood screws and distance pieces). Chassis can now be withdrawn to extent of speaker leads, which allow adequate slack for carrying out normal repairs.

To remove the chassis entirely, free speaker plug from socket.

Removing Speaker.—Take out the four round-head wood screws holding speaker to sub-baffle. When replacing, see that transformer is on right.

VALVE ANALYSIS

Readings of valve voltages and currents given in the table below were taken with the receiver operating on mains of 220 V, using the 220 V tapping on the mains transformer. Both the volume and sensitivity controls were at maximum, the receiver was tuned to the lowest wavelength on the medium band and there was no signal input.

Voltages were measured on the 1,200 V scale of an Avometer, with chassis as negative.

Valve	Anode Volts	Anode Current (mA)	Screen Volts	Screen Current (mA)
V1 6D6 ..	280	6.7	100	1.8
V2 6A7* ..	280	3.1	100	3.2
V3 6D6 ..	280	6.0	100	1.7
V4 85 ..	20	0.8	—	—
V5 76 ..	130	5.4	—	—
V6 45 ..	270	36.0	—	—
V7 45 ..	270	36.0	—	—
V8 80 ..	385†	—	—	—

* Osc. anode (G2) 155 V, 4.0 mA
† Each anode, A.C.

(Continued overleaf)

FERGUSON 350 (Continued)

GENERAL NOTES

Switches.—There are no fewer than twenty-seven single-pole wavechange switches, in four ganged rotary units. Each unit is in two sections, with three or four switches in each section. Each section has one common tag, and a rotary contact brings in each switch in the section in turn. There is an exception to this, for in the case of **S21**, **S22** and **S23** the rotary contact closes two switches in each of the S.W. positions. We give a diagram of the switch units, in the order and position in which they are seen looking from the rear of the underside of the chassis. The table below gives the switch positions for the four settings of the control knob, O indicating open, and C closed.

Switch	S.W.1	S.W.2	M.W.	L.W.
S1	C	O	O	O
S2	O	C	O	O
S3	O	O	C	O
S4	O	O	O	C
S5	O	O	O	O
S6	O	O	O	O
S7	O	O	O	O
S8	O	O	O	O
S9	O	O	O	O
S10	O	O	O	O
S11	C	O	O	O
S12	O	O	O	O
S13	O	O	O	O
S14	O	O	O	O
S15	O	O	O	O
S16	O	O	O	O
S17	O	O	O	O
S18	O	O	O	O
S19	O	O	O	O
S20	O	O	O	O
S21	C	O	O	O
S22	C	O	O	O
S23	C	O	O	O
S24	O	O	O	O
S25	O	O	O	O
S26	O	O	O	O
S27	O	O	O	O

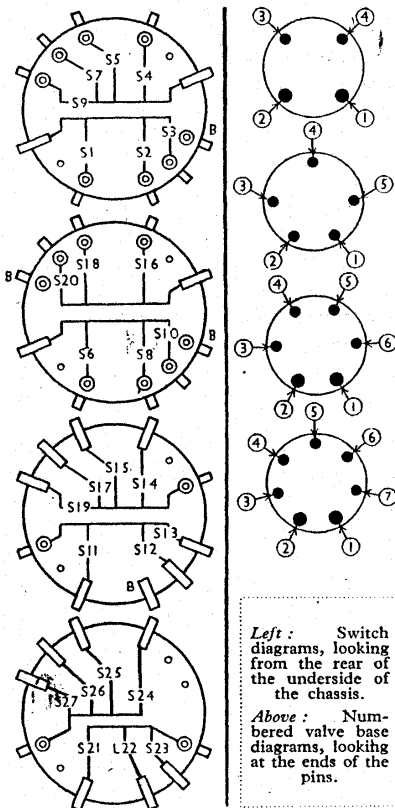

Left: Switch diagrams, looking from the rear of the underside of the chassis.

Above: Numbered valve base diagrams, looking at the ends of the pins.

The only other switch is **S28**, the Q.M.B. mains switch, ganged with **R11**.
Coils.—These are in five screened units on the chassis deck. Each of the signal frequency and oscillator units has four trimmers, while the I.F. units have the usual two trimmers. In certain cases coils shown separately in our circuit

diagram are really formed by single coils suitably tapped.

Trimmers C46, C47.—These are adjusted from the chassis deck.

Condenser C10.—This comprises two-fixed condensers and a trimmer, all in parallel.

Scale Lamps.—These are 6.3 V M.E.S. types with tubular bulbs.

External Speaker.—No provision is made for this, but a low resistance type could be connected across the speech coil tags of the internal speaker (behind the speaker transformer).

A1, A2 and G Terminals.—A1 is the normal aerial terminal, and A2 and G should be joined and connected to earth. When a transmission line aerial is used the output leads of the set matching transformer should go to A1 and A2, G being isolated.

Condensers C18, C23.—These are in a single unit with a common negative (black) lead. The positive of C18 goes to one socket of V4, and that of C23 to one socket of V5.

Valve Connections.—We give diagrams of the valve bases viewed from the undersides, with the pins numbered. The connections are as follow:

V1 and V3. 1 and 2, Heater; 3, Anode; 4, Scr. Grid; 5, Supp. Grid; 6, Cathode; Top Cap, Cont. Grid.

V2. 1 and 2, Heater; 3, Anode; 4, Scr. Grids; 5, Osc. Anode; 6, Osc. Grid; 7, Cathode; Top Cap, Cont. Grid.

V4. 1 and 2, Heater; 3, Anode; 4 and 5, Diode Anodes; 6, Cathode; Top Cap, Cont. Grid.

V5. 1 and 2, Heater; 3, Anode; 4, Cont. Grid; 5, Cathode.

V6 and V7. 1 and 2, Filament; 3, Anode; 4, Cont. Grid.

V8. 1 and 2, Filament; 3 and 4, Anodes.

Oscillator Circuit.—This may have slightly different connections from those shown in our circuit diagram, but the divergencies are unimportant.

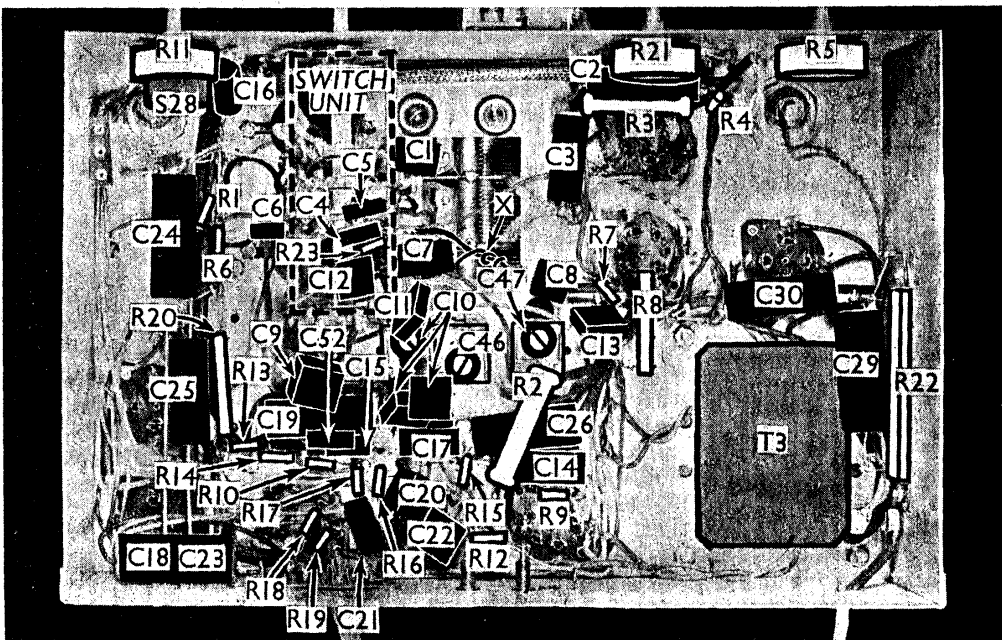

Under-chassis view. Separate diagrams of the four rotary switch units are in Col. 2. Note that C10 consists of one pre-set and two fixed condensers in parallel. C18 and C23 are in a single unit. R22 is an "armoured" resistance.